

# NoroGard westrup K7 Continuous Seed Treater

The K7 Continuous Seed Treater is designed for small and mid sized seed plants.

It stands for a reliable seed treater that is applying the treating liquids and powders with high accuracy and quality.



CAPACITY

**3-7 ton/hour**

The K7 Continuous Seed Treater is suitable for small and mid sized seed plants with a need for treatment of cereals, corn, peas, soybeans, rape seed, sunflower, etc.

**NoroGard  westrup**

# K7 Continuous Seed Treater

The Continuous Seed Treater Meets the Requirements for:

- Correct Dosage Rate
- High Application Quality
- Easy to Operate and Clean
- Operator Safety
- Reliability
- High Quality
- Minimal Service Needed

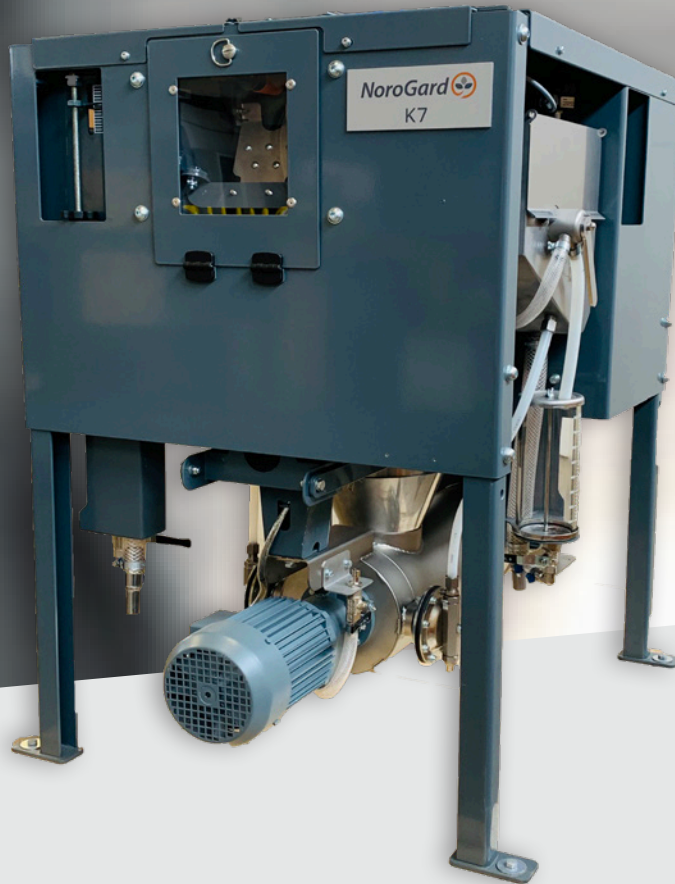

The K7 Continuous Seed Treater is suitable for small and mid sized plants with its variable capacity of up to 7 tons of seed per hour and dosing rates from 100 ml to 2.4 litres per 100 kg seed.

The compact and reliable construction of the K7 Continuous Seed Treater supports accurate application of treating liquid and/or powder with an easy dosage calibration within a closed system. It is also easy to operate and provides quick and easy cleaning.

The K7 model holds a small PLC to program the volume weight of your seed, statistics to inform how much you have treated, and you can program the K7 to stop at treated seed volume limit. The seed is fed through an intake and into a seed metering wheel that measures the volume of the seed into 12 pockets, this way you will always have an exact measurement of volume seed fed into the machine. The seed then continues into the application zone where the treating liquid is applied in a mist to finish in the mixing tube with a gentle post-mixing process.

The K7 provides an option of 1 or 2 dosage system including option for a wide dosage rate system where the machine can operate either with one system separate or with two at the time. The calibration and/or checking of the dosage rate takes place within a closed system of which seed or treatment does not pass through so you will not contaminate any seed during calibration.

The K7 Continuous Seed Treater is also equipped with a supervision and security system that stops the machine if the seed flow is interrupted, and automatically starts back up when the seed flow returns. Same goes if there is not enough treating liquid to provide an accurate dosage.

The K7 is approved for the European CE workers safety standard.

## TECHNICAL SPECIFICATION

Power requirement	3.0 kW
Capacity [wheat with density 850 kg/m <sup>3</sup> ]	2.8-7 ton/hour
Dosage system	1-2 [see options]
Dosage rate	100-2200 ml/100kg
Standard	100-600 ml/100kg
HDR	500-2200 ml/100kg
Weight	241 kg
Width	722 mm
Depth	1253-2088 mm
Height	1005-1205 mm
Warranties	Orgalime S2012



The K7 Continuous Seed Treater is easy to clean and operate.

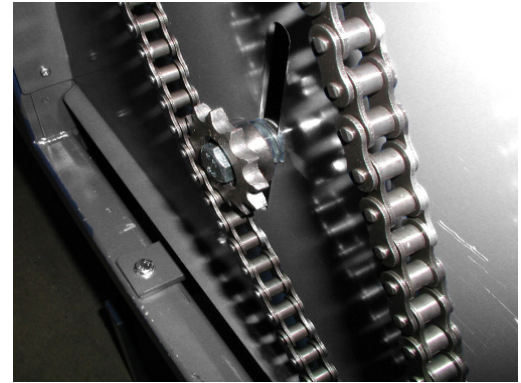

Our machines are built to last for 20 years.

The Continuous Seed Treaters are recommended for production of volume seeds. The treaters has an even flow of both seeds and the treating liquids that is continuously measured.

## OPTIONS

- Dosing system with transport pump. Maximum of 2 dosage systems.
- Prehopper with extension 200 L
- Double bagging unit
- Extra mixer
- Powder dosing unit including extra mixer, powder feeder and control system.
- Remote control panel with start/stop.
- Suction lance with filter, 1.1 meter.
- Premix tank 200, 400 or 600 L.
- Mixer station, 1000 L. IBC.
- IBC Mixer with bracket for 1000 L IBC.

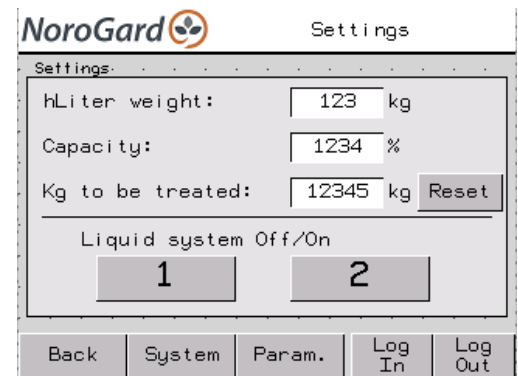

K7 settings on PLC screen.

## K7 CONTINUOUS SEED TREATER · MEASUREMENTS

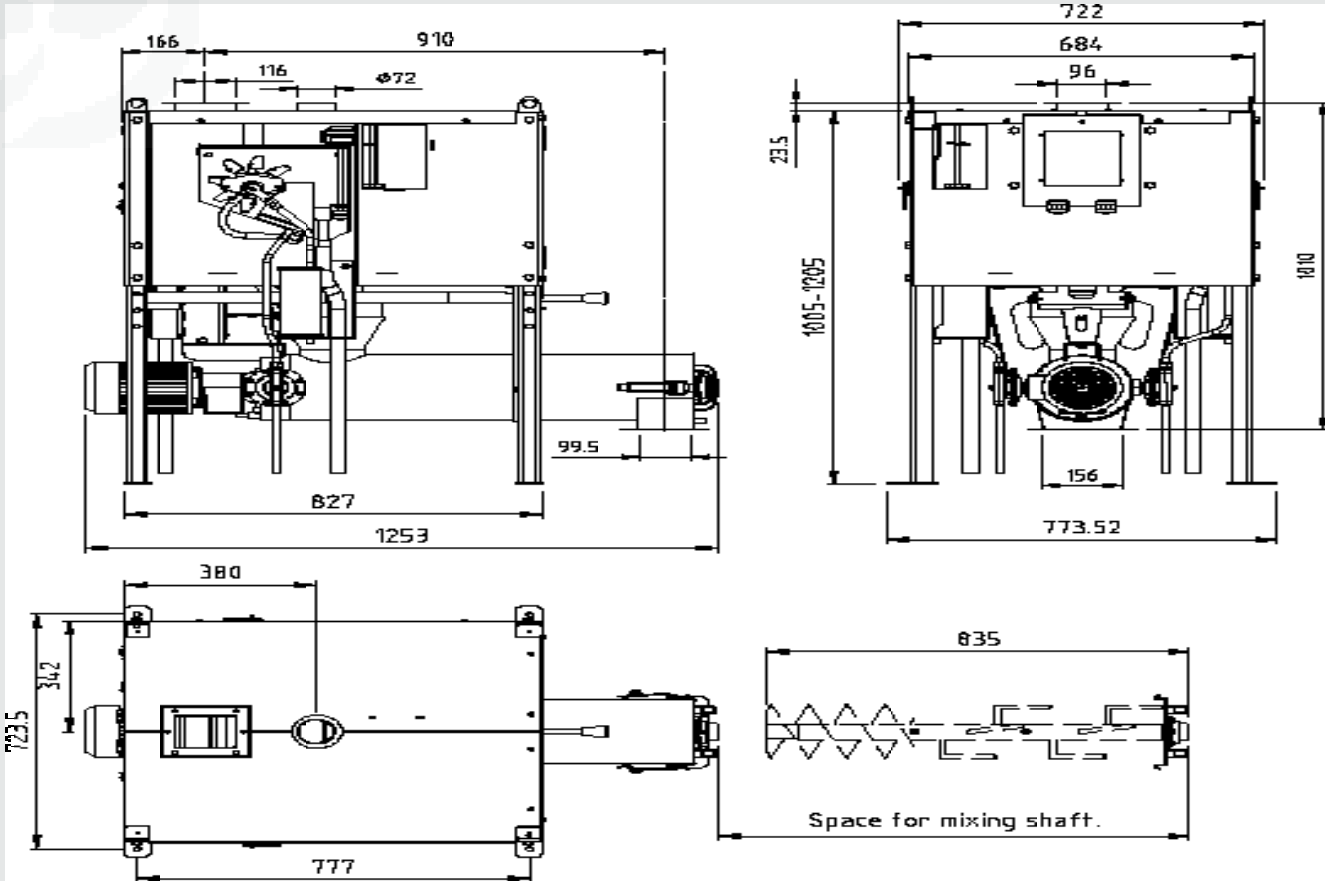

## NOROGARD · WESTRUP

NoroGard was founded in Sweden where the development and production of high quality Seed Treatment Equipment began in 1965. In 2022 the production of Seed Treatment Equipment was taken over by Westrup A/S in Denmark.

The NoroGard · Westrup seed treaters are designed to be extremely reliable and built to last for more than 20 years. The NoroGard dosage systems are unique and equipped with pumps and flow meters of our own design, in order to offer you the best possible application quality and reliability.

Personal service and customization is key. NoroGard · Westrup delivers sophisticated Seed Treaters worldwide with personal support. The seed treaters are built to last. Should a standstill occur in spite, we always keep your spareparts in stock.

### OUR INNOVATIONS

The pumps are one of our innovations developed and made in-house and specially designed to perform under tough conditions.

The Diaphragm pump is outstanding in reliability and low maintenance compared to any peristaltic pump on the market.

Our pumps have a pressure equalization for an even flow with less pulses, which insures high dosing accuracy. The pumps are also reversible, easy to operate and have a long life cycle.

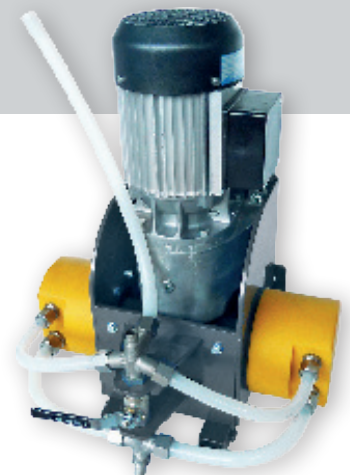

# NoroGard · westrup

Westrup A/S,  
DK-4200 Slagelse, Denmark  
+45 58 52 25 64  
info@westrup.com  
www.westrup.com