

NoroGard **westrup** R1 Continuous Seed Treater

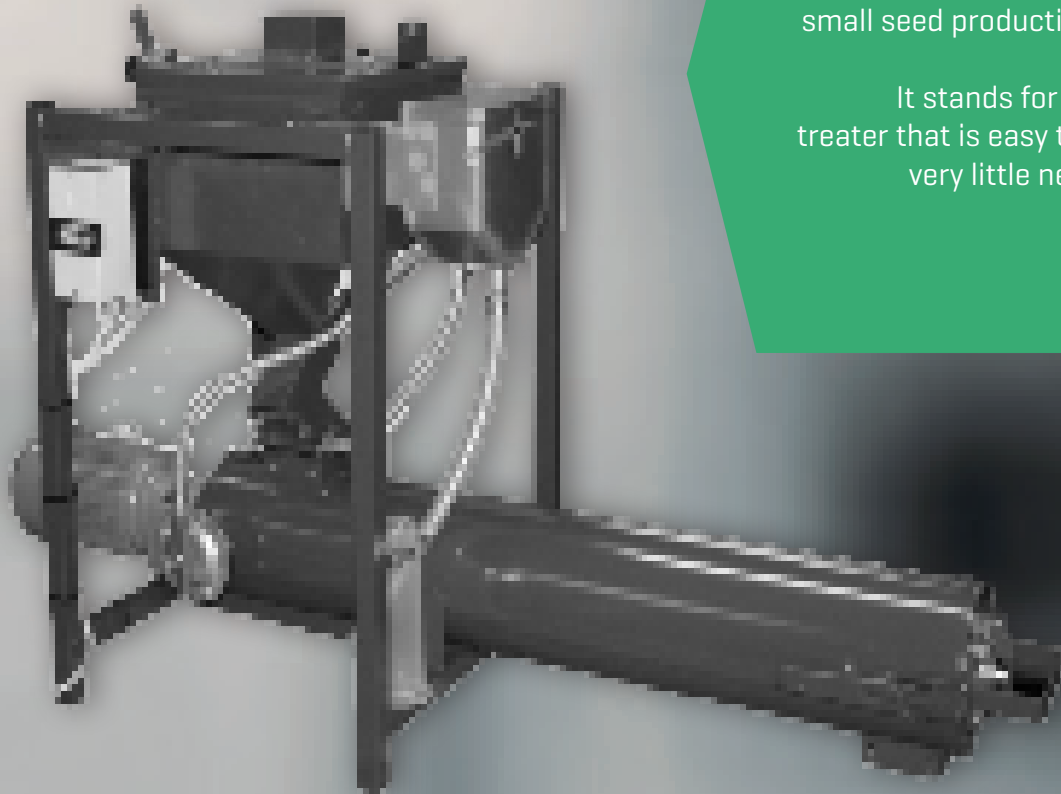

The R1 Continuous Seed Treater is designed for on farm use or for small seed production companies.

It stands for a reliable seed treater that is easy to operate with very little need for service.

CAPACITY

2,5 ton/hour

The R1 Continuous Seed Treater is suitable for on farm use or for small seed production companies. It is designed for treatment of wheat, barley, rye, oat, corn, peas, soybeans, sunflower seeds etc. with liquids.

NoroGard  **westrup**

R1 Continuous Seed Treater

The Continuous Seed Treater Meets the Requirements for:

- Correct Dosage Rate
- High Application Quality
- Easy to Operate and Clean
- Operator Safety
- Reliability
- High Quality
- Minimal Service Needed

The R1 Continuous Seed Treater are recommended for processing of volume seeds. The treater has an even flow of both seeds and the treating liquids that is continuously measured.

The R1 Continuous Seed Treater is suitable for on farm use or for small seed production companies. The simple and suitable design makes the machine ideal for continuous seed treatment of up to 2,5 tonnes of wheat* per hour. It is also suitable for the treating of barley, rye, oat, corn, peas, soybeans, sunflower seeds etc.

The R1 works fully automatic once the seed and treatment product are supplied. An even distribution of the product and an effective mixing with the seed is achieved in the rotating mixer.

The treater is as standard equipped with connection pipes at the inlet and outlet. The outlet is prepared for mounting a bagging unit. See the list of options for possible alterations suitable for your use.

The Continuous Seed Treater has an even flow of seed through the machine. The seed flow and the flow of treating liquids are continuously measured. The application of the liquids on the seed takes place in two steps.

The primary application is in an area where the treatment liquid is applied. In a second step there is an extra mixing in a tube also carrying the seed to exit.

The R1 is approved for the European CE workers safety standard.

* Wheat with a density of 850kg/m³.

TECHNICAL SPECIFICATION

Power requirement	0,55 kW
Capacity [wheat with density 850 kg/m ³]	2,5 ton/hour
Dosage system	1-2 [see options]
Dosage rate [per system]	600-1200 ml/100kg
Weight	50 kg
Width	730 mm
Depth	500 mm
Height	1400 mm
Warranties	Orgalime S2012

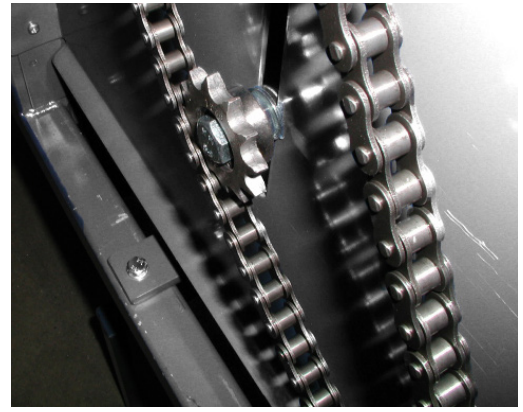

Our machines are build to last for 20 years.



The R1 stands for a reliable and compact seed treater that requires minimal service and is easy to operate.

OPTIONS

- Pre-bin 100 litre.
To be mounted on top of the machine.
- Frame/leg construction.
Is made so the machine can be installed 945 mm over the floor.
- Wheels.
Increases the height with 135 mm and makes the treater portable.
- Liquid barrel with manual mixer.
Gives the opportunity to mix and dilute the treating liquid with, for example, water.
- Lance with filter.
To connect the suction hose and prevent dirt to reach the pump.
- Extra dosage system.
Gives the possibility to run the machine with 2 treating liquids separately or together.
- Guard for liquid supply.
Stops the treater if the treating liquid runs out.
- Double bagging unit.
For bagging out directly after the treater.
- Exhaust equipment.
Take care of the dust from the process. Improving application quality and working environment.

R1 CONTINUOUS SEED TREATER · MEASUREMENTS

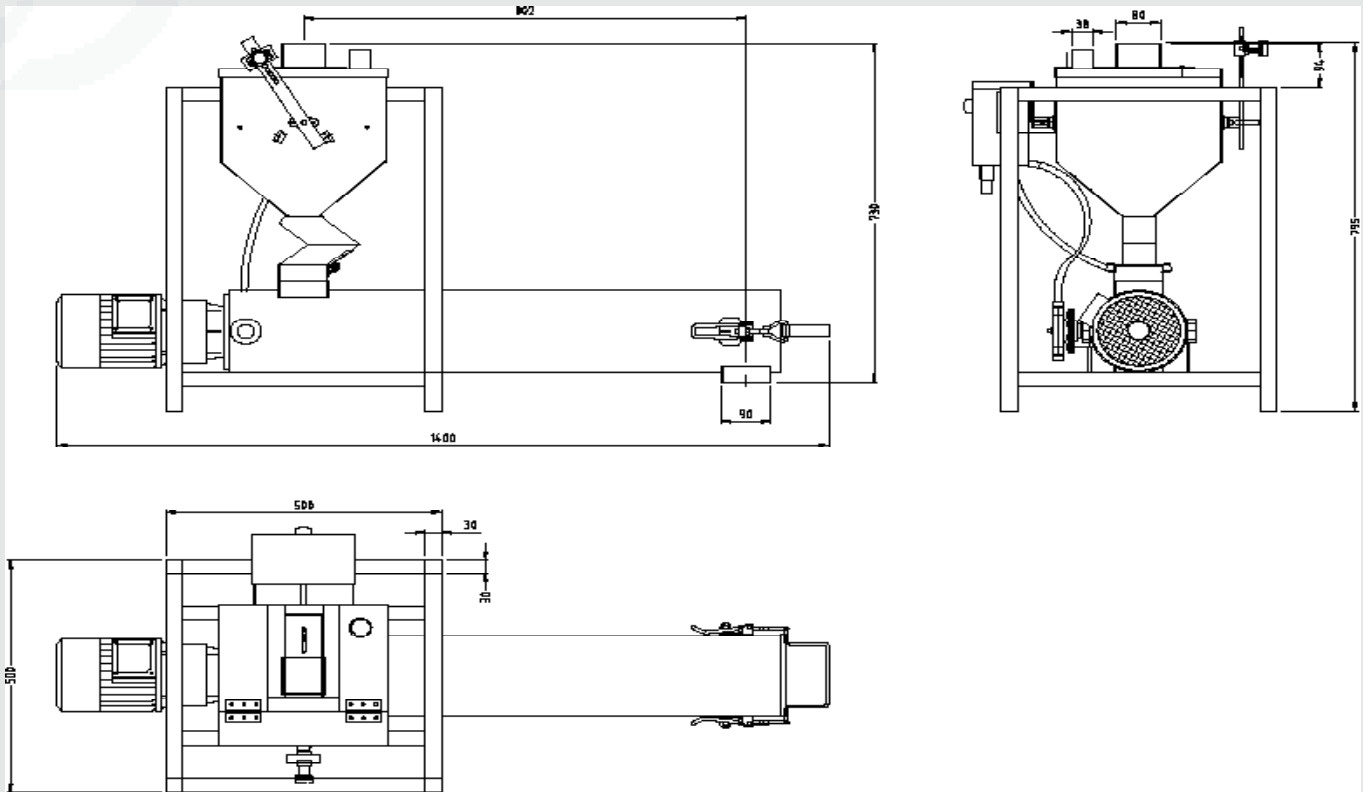

NOROGARD · WESTRUP

NoroGard was founded in Sweden where the development and production of high quality Seed Treatment Equipment began in 1965. In 2022 the production of Seed Treatment Equipment was taken over by Westrup A/S in Denmark under the NoroGard · Westrup fusion.

The NoroGard · Westrup seed treaters are designed to be extremely reliable and built to last for more than 20 years. The NoroGard dosage systems are unique and equipped with pumps and flow meters of our own design, in order to offer you the best possible application quality and reliability.

Personal service and customization is key. NoroGard · Westrup delivers sophisticated Seed Treaters worldwide with personal support. The seed treaters are built to last. Should a standstill occur in spite, we always keep your spareparts in stock.

OUR INNOVATIONS

The NoroGard · Westrup pumps are one of our innovations developed and made in-house and specially designed to perform under tough conditions.

The Diaphragm pump is outstanding in reliability and low maintenance compared to any peristaltic pump on the market.

Our pumps have a pressure equalization for an even flow with less pulses, which insures high dosing accuracy. The pumps are also reversible, easy to operate and have a long life cycle.

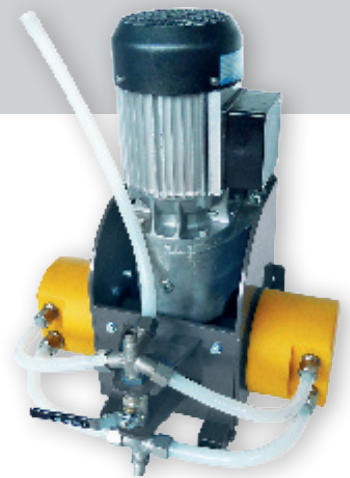

NoroGard westrup

Westrup A/S,
DK-4200 Slagelse, Denmark
+45 58 52 25 64
info@westrup.com
www.westrup.com